

FPM-154 & FPM-154T



LCD Monitor User Guide

FPM-154 & FPM-154T

Table Of Contents

Section 1 Introduction

About LCD Monitors
Product Safety Precautions

Section 2 Display Setup

Included Parts
Connecting Your Display

Section 3 Getting Started

Display Features
Getting Started
Adjusting the Display
Using the Auto-Adjust
OSD (On Screen Display) Adjustments

Section 4 Touch Screen Set up

Introduction to Touch Screens
Touch Screen Driver Installation
 Windows 98
 Windows NT 4.0
 Windows 2000
 Windows XP

Section 5 Mounting Instructions

Section 6 Trouble Shooting Tips

Section 7 Cleaning and Maintenance

Section 8 Appendices

A-VGA Pin Assignment
B-RS-232 Pin Assignment
C-General Specifications
D-Mounting Dimensions

1

Section

LCD Introduction

About LCD Monitors

What you gain by using an LCD monitor for your industrial display is the future of display technology. CRTs although they have dropped in cost significantly, do not offer the performance, reliability, and mounting options available with LCDs. LCD monitors consist primarily of an LCD, video board and a backlight. The LCD determines to a large extent the viewing angle, brightness and contrast. Beyond that it is the function of the video board, which converts the analog RGB (Red, Green, Blue) signals from a standard video card to a high quality, digital RGB that the LCD can display.

LCD monitors can be set for one or more of the following resolutions:

VGA: 640 x480
SVGA: 800x600
XGA 1024 x 768
SXGA 1280 x1024
UXGA 1600x 1200

Note: The VGA acronym stands for Video Graphics Adapter. It is used to describe both the most common type of display interface used by PC's and lowest resolution setting for this interface. Originally only the VGA [640x480] resolution was available on a VGA interface. Today all of the above interfaces are available on a VGA interface, but not all monitors support all resolutions. . The native resolution of the LCD is normally the maximum resolution that the LCD can display, and is the resolution that the LCD will exhibit the best display characteristics Check the monitor specifications (Appendix C) for the resolutions supported by this monitor.

Recently the video card has taken on a new role. It is the responsibility of this device to "scale" a particular video resolution to the "native" resolution of the LCD. This enables a computer set to output a VGA [640x480] resolution signal to be properly displayed on an XGA [1024x768] LCD screen. Without the scaling engine, the displayed picture would be in the center $\frac{1}{3}$ of the LCD. The scaling engine mathematically converts the 640x480 to 1024x768. This may sound simple but it is in fact a complex algorithm that adjusts for different aspect ratios and pixel alignment, essentially smoothing text and graphics to produce a picture that is pleasant to the eye.

All IED displays from 12.1" (800x600) to 18.1" (1280x1024) incorporate scaling engines in the converter card.

Safety Precautions

CAUTION: SHUT OFF YOUR TOUCH SCREEN BEFORE CLEANING!!

IF YOUR DISPLAY IS A “T” MODEL, THAT IS A TOUCH SCREEN DISPLAY, THE SCREEN WILL BE ACTUATED BY CLEANING. PRESSING ON THE SCREEN WHILE CLEANING WILL BE SEEN AS A TOUCH TO THE SYSTEM WHICH COULD CREATE A POTENTIALLY DANGEROUS CONDITION!!

- ✎ Do not attempt to service this display yourself. The rear chassis has a seal so that non qualified personal will not expose themselves to dangerous voltages or other risks.
- ✎ To protect from electrical shock, unplug the display power supply from the wall before moving.
- ✎ Do not use this display near water
- ✎ Do not place any heavy objects on the power cords. Damage may cause electrical shock.
- ✎ Unplug the power supply from the wall or unit if one of the following conditions exists.
 - Power cord or plug is damaged or frayed
 - Liquid is spilled into the display or the display is exposed to rain or water.
 - The display does not operate normally when the operating instructions are followed.
 - The display has been dropped or the enclosure has been damaged.
 - The display exhibits a distinct change in performance, indicating a need for service.
- ✎ Ensure that sufficient space is available around the display to provide air circulation for cooling.
- ✎ Ensure that the ambient air temperature will not exceed the specified maximum temperature.
- ✎ Do not expose the display to direct sunlight or heat.

2

Section

Display Setup

Your LCD monitor package will consist of the primary components listed below.

Open shipping container and lay all components on a flat clean surface.

- ✦ FPM-154(T) LCD Monitor
- ✦ 6 ft Video Cable
- ✦ 6 Ft AC Power Cable
- ✦ 6 ft RS232 Touch Interface Cable (touch screen units only)
- ✦ 10-32 Mounting Hardware. (For use with Panel Mount)
- ✦ Documentation and Driver CD ROM

Connecting Your Display

1. Connect all cables to the computer first. This includes the VGA cable, and if the unit has a touch screen, the RS 232 serial touch screen connection.
2. After connecting the cables between the LCD monitor and the computer, plug supplied AC power cord into a suitable AC outlet then into the LCD.
3. Power on the display. The On/Off switch is located where the AC power cord enters the unit
4. If your computer is off, turn on your computer.
5. Your display should now operate as a normal computer display, displaying the computers BIOS screens and booting into Windows or other operating system.

Note: If for any reason the display goes blank and/or displays “out of Range” or “No Input Signal” message on the screen, your computer or video source may be putting out a signal that is incompatible with the FPM-154(T). If this happens, reboot the computer with the previous display and adjust the display settings to be within the FPM-154(T) specifications (see Appendix C). Below is are the most common reasons a display may not operate correctly:

1. The resolution is to high or low for the LCD.
2. The refresh rate is set to high. Refresh on an LCD is different than a CRT. Set the refresh to 60Hz. CRT's need a high refresh rate to avoid flicker. The refresh rate has no impact on an LCD.
3. The power source is incorrect, or there is no power. Check if the rear LED is ON or blinking. If the LED is not lit, check to be sure there is power to the unit.

The unit is malfunctioning. If you believe this to be true, disconnect the video cable from the rear of the LCD and connect to a known good display. If the computer display is working satisfactory and the video is within the appropriate range, then contact IED technical support

3

Section

Getting Started

Display Features

- ✦ The FPM-154(T) is capable of displaying 16M (24 Bit) colors in a continuous spectrum. The high contrast LCD enhances the image with no geometric distortion.
- ✦ FPM-154(T) Series directly accepts an analog 3,4, or 5 wire RGB with separate H/V, composit, or sync on green. This is the standard PC video signal.
- ✦ The FPM-154(T) Series is auto synchronous adjusting the display to the appropriate input between VGA and SXGA (Note: XGA is the displays native mode, SXGA is interpolated).
- ✦ The FPM-154(T) Series is supplied with a Anti-Glare Touch Screen [TS models] or an Anti-Glare impact window on non touch screen models.
- ✦ The FPM-154(T) Series has an integrated 115/220VAC power supply as standard on all models.

Adjusting the Display

The FPM-154(T) Series display has an embedded microprocessor in the converter card [this is the electronics that drives the LCD], and has been recently updated with a more powerful chip set. In most cases the unit will require very little if any user intervention to operate correctly. That is, produce a sharp stable picture.

The micropocessor in the display has the capability to adjust itself to the computer to which it is attached. This autoadjustment will take place when the unit is first installed and connected to a computer and there after, if the video input changes, or is user initiated. If the picture is not satisfactory, the first step is to allow the unit to attempt to re-adjust itself to your computer.

Located on the rear of the unit is a membrane keypad used for adjusting the display. See figure 1 below:

Figure 1

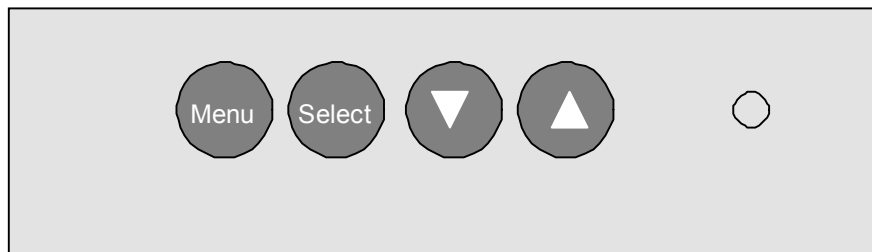

Using the Auto-Adjust

The FPM-154(T) will attempt to adjust itself to your computers current video model. If the picture is stable, and centered vertically and horizontally the automatic adjustment is complete. If however the picture is not stable, and centered vertically and horizontally you can re-initiate the auto-adjustment. Once you have the unit displaying the resolution you desire for your application do the following:

Press and release the “Select” button on the membrane. This will place the unit into a “Geometry Auto Adjust” mode. This operation will adjust the picture so it is centered both vertically and horizontally on the LCD screen. It will also make the necessary adjustments to the internal clock timing so that the picture is stable (without any discernable pixel jitter).

After having completed this step you may wish to adjust the color balance. This procedure adjusts for any imbalance in the Red, Green, and Blue levels from the video cable or video card. This is accomplished using the LCDs OSD (On Screen Menu) system.

OSD (On Screen Display) Adjustments

There are four membrane buttons (see Fig 1, above) located on the rear of the unit. They will activate the OSD and allow navigation to all adjustments if your unit requires adjustment.

Press MENU key, OSD screen appears. [See Figure 2]



Press UP/DOWN key, you can move between the five primary functions:
Press Select key at Picture group to highlight this sub menu. You can now navigate the sub menu using the UP/DOWN keys. To make an adjustment to an item press Select and use the UP/DOWN buttons to make your adjustments

At anytime, press the Menu button Two times to Exit and Save your settings.
This convention of Menu, Navigate, Select Sub Menu, Navigate, Select Item and adjust is used throughout the OSD screen process.

Press MENU key to return previous state and press MENU key twice to exit OSD.

PICTURE

Press MENU key to bring up the OSD. Press UP/DOWN key, to move between the 5 primary screen functions. Press the Select button at Picture, to select it. Press the UP/DOWN key, you can now move between functions and press Select to adjust the value of each item with the UP/DOWN key. Press MENU key to return previous state and press MENU key twice to exit OSD.

- ✎ BRIGHTNESS Function of adjusting main screen brightness.
- ✎ CONTRAST Function of adjusting main screen contrast.
- ✎ FREQUENCY Function of adjusting main screen sampling clock frequency.
- ✎ PHASE Function of adjusting main screen sampling clock phase.
- ✎ H POSITION Function of adjusting the horizontal position of main screen .
- ✎ V POSITION Function of adjusting the vertical position of main screen .

ADVANCED

Press MENU key to bring up the OSD. Press UP/DOWN key, to move between the 5 primary screen functions. Press the Select button at Advanced, to select it. Press the UP/DOWN key, you can now move between functions and press Select to adjust the value of each item with the UP/DOWN key. Press MENU key to return previous state and press MENU key twice to exit OSD.

- ✎ Color Temp Function of setup of main color. (Bluish, Normal, Reddish)
- ✎ User RED Function of adjusting value of RED.
- ✎ User BLUE Function of adjusting value of BLUE.
- ✎ User GREEN Function of adjusting value of GREEN.
- ✎ Gamma Function of adjusting value of color ratio.

COLOR WARP

Press MENU key to bring up the OSD. Press UP/DOWN key, to move between the 5 primary screen functions. Press the Select button at Color Warp, to select it. Press the UP/DOWN key, you can now move between functions and press Select to adjust the value of each item with the UP/DOWN key. Press MENU key to return previous state and press MENU key twice to exit OSD

- ✎ Color Warp Function of adjusting curve on main screen.
- ✎ Mode Function of selecting curve on main screen.
- ✎ Custom Center Function of adjusting color warp on center.
- ✎ Custom range Function of adjusting range on color warp.
- ✎ Saturation Function of adjusting saturation warp on center.
- ✎ Custom hue Function of adjusting the tone of color.

OPTIONS

Press MENU key to bring up the OSD. Press UP/DOWN key, to move between the 5 primary screen functions. Press the Select button at Options, to select it. Press the UP/DOWN key, you can now move between functions and press Select to adjust the value of each item with the UP/DOWN key. Press MENU key to return previous state and press MENU key twice to exit OSD

- ✎ Osd V Pos Function of adjusting the vertical position of OSD image .
- ✎ Osd H Pos Function of adjusting the horizontal position of OSD image.
- ✎ Osd Function of moving OSD image quickly.

UTILITIES

Press MENU key to bring up the OSD. Press UP/DOWN key, to move between the 5 primary screen functions. Press the Select button at Utilities, to select it. Press the UP/DOWN key, you can now move between functions and press Select to adjust the value of each item with the UP/DOWN key. Press MENU key to return previous state and press MENU key twice to exit OSD

- ✎ OSD Timeout Function of adjusting OSD disappear time .
- ✎ OSD Bkground Function of adjusting at transparency on main screen to osd image.
- ✎ Auto Adjust Function of finding optimized main screen automatically.
- ✎ Factory Reset Function of resetting all value on OSD.
- ✎ Power On Time Function of indicating system on time.
- ✎ Bklight OnTime Function of indicating panel on time.

4

Section

Touch Screen Setup

Introduction to Touch Screens

Touch screen interfaces have become the standard interface in the past 5 years. They are, rugged, reliable, extremely flexible and easier than ever to implement! The universal acceptance of the Windows GUI [Graphical User Interface] along with the extensive use of a mouse interface has significantly accelerated the use of a touch interface. Basically think of your touch screen as if it were a mouse.

IED touch systems are mouse emulators. By installing a software driver and connecting to a serial port, the touch screen will support all the primary mouse functions:

The FPM-154(T) touch screen interface, is a high resolution, analog resistive. Following is a quick explanation of what all this means.

High Resolution: The touch screen resolution is 400 ppi [points per inch]

Analog Resistive: The actual touch glass is an analog device. Meaning there is a very low voltage applied to the X and Y axis of the touch screen. This current is applied to ITO [Iridium Tin Oxide] that is sputtered onto a polyester membrane. When you touch the screen you are changing the resistance on both the X and Y axis, producing an analog value that references a particular location.

This type of screen can be activated with a gloved finger or mechanical stylus.

The touch screen itself is connected to electronics [internal to the display unit] that provide the Analog to Digital conversion. When the screen is touched, the electronics convert the analog voltage to a digital value and add a "Mouse Click". This touch data is sent out from the display serial port to the PC serial port where the touch driver presents the data to the operating systems as if it were from a normal PC mouse. When the touch is released the new XY location is sent along with a "Mouse Up Click".

The touch screen interface to the PC is RS-232, so the recommend maximum distance from the PC is 50 feet., The driver and and interface have been tested to 50 Ft. using high quality cables. High quaility cables and connectors are important, especially if field connections are made. Poor quality cables will drastically reduce the performance of the RS-232 interface. The touch driver default baud rate is 9600.

Touch Screen Setup and Configuration:

If the unit does not have a touch screen, your configuration is complete. If your display is fitted with the optional touch screen interface, the following section will outline installation and set up. This system requires no special software knowledge, and can be installed and set up in minutes. The following section gives a detailed explanation of the software setup and configuration

Touch Screen Driver Installation for *Windows 98*

Required items to **know** or **have** to install the Touch Driver.

- ✦ What Operating System you are using. **Windows 98**
- ✦ What Serial Port you are connected to. **Usually COM 1 or COM 2**
- ✦ The type of touch screen. **Smartset**
- ✦ The CD-ROM or Floppy disk included with the system.

Touch Screen Driver Installation for *Windows 98*

- ✦ Insert the provided CD
- ✦ Select Link to the Windows 98 driver
- ✦ Select **Open** from the Windows dialog box.
- ✦ Select **SmartSet** Controller for Com1 or Com2
- ✦ Remove the CD.
- ✦ Restart the computer; you will be prompted to calibrate the touch screen.
- ✦ Touch each of the 3 targets as directed. If the unit does not respond to your calibration touches then you have probably selected the wrong COM port. If so, reinstall the driver and selecting the correct COM port.
- ✦ You are now ready to use your touch screen.

Note 1: The touch screen calibration information is maintained in the computer. If you change computers, you will need to reinstall the touch screen driver software and recalibrate.

Note 2: If for any reason the touch screen performance is unsatisfactory, you can recalibrate at any time. This is done from the ELO icon under the Windows control panel

Touch Screen Driver Installation for *Windows NT 4.0*

Required items to **know** or **have** to install the Touch Driver.

- ✎ What Operating System you are using. **Windows NT 4.0**
- ✎ What Serial Port you are connected to. **Usually COM 1 or COM 2**
- ✎ The type of touch screen. **Smartset**
- ✎ The CD-ROM or Floppy disk included with the system.

Touch Screen Driver Installation for Windows NT 4.0

- ✎ Insert the provided CD
- ✎ Select Link to the Windows NT driver
- ✎ Select **Open** from the Windows dialog box.
- ✎ Select **Next**
- ✎ Select **Yes** - To the license agreement
- ✎ Select **Next** - To the default installation folder
- ✎ Select **Next** - For Single Monitor installation
- ✎ Select the Com Port to which the touch interface is connected and **Next**
- ✎ Select **Finish**
- ✎ Remove the CD.
- ✎ Restart the computer. You will be prompted to calibrate the touch screen.
- ✎ Touch each of the 3 targets as directed. If the unit does not respond to your calibration touches then you have probably selected the wrong COM port. If so, press the Esc key on the keyboard to exit.
- ✎ Go to the ELO icon under Windows Control Panel.
- ✎ Select the correct Com Port, and Restart the computer.
- ✎ If this fails, reinstall the driver and select the correct COM port
- ✎ Once restarted, select the ELO icon under Windows Control Panel
- ✎ Select **Calibrate**, and then touch each of the 3 targets as they are displayed.
- ✎ You are now ready to use your touch screen.

Note 1: The touch screen calibration information is maintained in the computer. If you change computers, you will need to reinstall the touch screen driver software and recalibrate.

Note 2: If for any reason the touch screen performance is unsatisfactory, you can recalibrate at any time. This is done from the ELO icon under the Windows control panel

Touch Screen Driver Installation for *Windows 2000*

Required items to **know** or **have** to install the Touch Driver.

- ✎ What Operating System you are using. **Windows 2000**
- ✎ What Serial Port you are connected to. **Usually COM 1 or COM 2**
- ✎ The type of touch screen. **Smartset**
- ✎ The CD-ROM or Floppy disk included with the system.

Touch Screen Driver Installation for *Windows 2000*

- ✎ Insert the provided CD
- ✎ Select Link to Windows 2000 driver
- ✎ Select **Open** from the Windows dialog box.
- ✎ Select **Next**
- ✎ Select **Yes** - To the license agreement
- ✎ Select the Com Port to which the touch interface is connected and Next
- ✎ Select **Next**, the driver will now start to install.
- ✎ Select **YES** - To continue
- ✎ Select **Finish**
- ✎ Remove the CD.
- ✎ Select **YES** to Restart.
- ✎ When the system restarts touch each of the 3 targets as directed.
- ✎ If the unit does not respond to your calibration touches then you have probably selected the wrong COM port. If so, press the Esc key to exit.
- ✎ Go to the ELO icon under Windows Control Panel.
- ✎ Select the correct Com port, and restart the computer.
- ✎ Once restarted, select the ELO icon under Windows Control Panel
- ✎ Select **Align and Calibrate**; then touch each of the 3 targets as directed.
- ✎ You are now ready to use your touch screen.

Note 1: The touch screen calibration information is maintained in the computer. If you change computers, you will need to reinstall the touch screen driver software and recalibrate.

Note 2: If for any reason the touch screen performance is unsatisfactory, you can recalibrate at any time. This is done from the ELO icon under the Windows control panel

Touch Screen Driver Installation for *Windows XP*

Required items to **know** or **have** to install the Touch Driver.

- ✦ What Operating System you are using. **Windows XP**
- ✦ What Serial Port you are connected to. **Usually COM 1 or COM 2**
- ✦ The type of touch screen. **Smartset**
- ✦ The CD-ROM or Floppy disk included with the system.

Touch Screen Driver Installation for Windows XP

- ✦ Insert the provided CD
- ✦ Select Link to XP driver
- ✦ Select **Open** from the Windows dialog box.
- ✦ Select Yes - To the license agreement
- ✦ Select the Com Port to which the touch interface is connected and Next
- ✦ Select **Next**, the driver will now start to install.
- ✦ Select **YES** - To continue
- ✦ Select **Finish**
- ✦ Remove the CD
- ✦ Select **YES** to Restart
- ✦ Go to the ELO icon under Windows Control Panel.
- ✦ Verify the Com Port is correct
- ✦ Select **Align**; then touch each of the 3 targets as directed.
- ✦ If the unit does not respond to your calibration touches then you have probably selected the wrong COM port. If so, press the Esc key to exit.
- ✦ Select the correct Com port, and restart the computer, then align the touchscreen.
- ✦ You are now ready to use your touch screen.

Note 1: The touch screen calibration information is maintained in the computer. If you change computers, you will need to reinstall the touch screen driver software and recalibrate.

Note 2: If for any reason the touch screen performance is unsatisfactory, you can recalibrate at any time. This is done from the ELO icon under the Windows control panel

5

Section

Mounting Instructions

Panel Mounting Procedure

1. Cut and drill the panel (refer to Figure 2; Panel Mount Drawing). Measurements are in inches. A template of the hole pattern has been supplied with your monitor to assist in making the mounting holes accurately. Also, there is an AutoCad .dxf file included on the provided CD. This computer file can be used in a design drawing or forwarded to your panel fabricator for the proper mounting
2. If access to the side of the monitor is not available following installation, attach the power and video cables to the side of the monitor at this time.
3. Install the monitor in the prepared cutout.
4. Install the washers and lock nuts supplied with the monitor.
Note: Use #10-32 nuts for mounting.
5. Tighten all mounting nuts evenly to a torque of 24 inch-pounds.

ATTENTION: Mounting nuts must be tightened to a torque of 24 inch-pounds to provide panel seal and avoid potential damage. IED assumes no responsibility for water or chemical damage to the monitor or other equipment within the enclosure due to improper installation.

6. Attach the power, video and touch screen cables (if this is a –TS unit) to the side of the monitor.

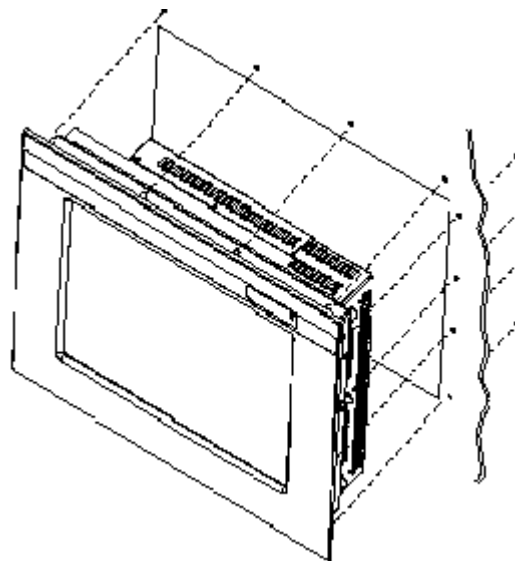

Figure 2: Panel Mount Drawing

6

Section

Troubleshooting Tips

No Picture	<p>Check that the signal cable is properly connected to the display.</p> <p>Try disconnecting the video cable from the display and connecting to another display if available to confirm the presence of proper video.</p> <p>Make sure power is connected to the proper AC source.</p> <p>Make sure the resolution mode is supported by the display and check display settings of the PC</p> <p>Confirm that the video cable is not defective.</p>
------------	---

Image Persistence	<p>Image persistence occurs when a ghost of an image remains on the screen after the screen image has been changed. Unlike a CRT monitor, an LCD monitor's image persistence is not permanent. To erase an image ghost, turn the monitor off for several hours. What happens is the the liquid crystals after extened periods of operation with take a "set". To avoid this condition, install a screen saver progam on the computer</p>
-------------------	--

Picture Quality & Image Stability	<p>Check for proper video cable for proper grounding and shielding.</p> <p>Check the signal source for proper signal.</p> <p>Check for proper adjustment of the Phase and Frequency controls.</p> <p>Check for proper recommended signal timing.</p>
-----------------------------------	--

Green LED not lit	Check for proper power and power connections
-------------------	--

Display image is not properly sized	<p>Press the "Select" button to Auto Adjust the display</p> <p>Adjust the Vertical and Horizontal size controls via the OSD. (Reference setup adjustments)</p> <p>Ensure that a supported mode is selected on the display card or system being used. Consult the display card or system manual for proper video.</p>
-------------------------------------	--

Image will not adjust	<p>Video timing outside of range.</p> <p>Use the on-screen menu to adjust the Clock Setting.</p> <p>Make sure timing is within VESA standard.</p>
-----------------------	---

Slight distortion in text or Graphics	Not working in native resolution.
---------------------------------------	-----------------------------------

Display is present but "bars" Appear or roll across screen	<p>Ground loop problem between computer and display</p> <p>Interference from adjacent equipment.</p>
--	--

Vertical shaded bars on Screen image	Horizontal size not properly adjusted. Adjust horizontal size
--------------------------------------	---

Image is not stable.	<p>Monitor has incorrect or bad sync signals..</p> <p>Check for proper video cable installation.</p> <p>Replace suspected faulty cable.</p> <p>Check to ensure that video source is within the display's operating range.</p>
----------------------	---

7

Section

Cleaning & Maintenance

Cleaning

CAUTION: SHUT OFF YOUR TOUCH SCREEN BEFORE CLEANING!!

IF YOUR DISPLAY IS A –TS MODEL, THAT IS A TOUCH SCREEN DISPLAY, THE SCREEN WILL BE ACTUATED BY CLEANING. PRESSING ON THE SCREEN WHILE CLEANING WILL BE SEEN AS A TOUCH TO THE SYSTEM WHICH COULD CREATE A POTENTIALLY DANGEROUS CONDITION!!

Occasionally clean the display panel and cabinet with a soft cloth dampened (not soaked) with a mild (non-abrasive) glass cleaner. Keep turning a fresh side of the cloth toward the screen surface to avoid scratching it with accumulated grit.

Note: The solvent should be applied only to the cloth, and not directly on the monitor screen.

Do not use paper products as they may scratch the surface. To minimize the risk of abrasion, allow the screen to air dry. Special care should be taken when cleaning a touch screen or polycarbonate shield that is installed over the screen. Abrasive and certain chemical cleaners can damage the surface.

Never use alcoholic or ammoniac cleaners to clean the polycarbonate shield or a touch screen.

Replacing a Line Cord

To avoid shock and fire hazards, the monitor's power cord should be replaced if the insulation becomes broken or if it develops a loose internal connection.

Other Maintenance

Qualified service personnel should perform all maintenance, except for the power cord replacement described above.

8

Section

Appendices

Appendix A – Video Pin Assignments

Pin assignments for the HD15 video connector

Pin 1	Red Video	Pin 9	No Connection
Pin 2	Green Video	Pin 10	Sync Ground
Pin 3	Blue Video	Pin 11	Not Used
Pin 4	Not Used	Pin 12	Bi-Directional Data
Pin 5	Return	Pin 13	Horizontal Sync
Pin 6	Red Video Ground	Pin 14	Vertical Sync
Pin 7	Green Video Ground	Pin 15	Data Clock (SCL)
Pin 8	Blue Video Ground		

Appendix B – RS-232 Pin Assignments

Pin assignment for 9 Pin Optional Touch Screen Connector

Pin 1	DCD	Data Carrier Detect
Pin 2	RD (Rx)	Receive Data
Pin 3	SD (Tx)	Transmit Data
Pin 4	DTR	Data Terminal Ready
Pin 5	SB	Signal Ground
Pin 6	DSR	Data Set Ready
Pin 7	RTS	Request to Send
Pin 8	CTS	Clear to Send
Pin 9	NC	No Connection

Appendix C –General Specifications

FPM-154 & FPM-154T

Bold - Indicates Up Dated Specification

Active Screen Area	11.97" x 8.98"
Brightness	450 Nit
Contrast	300:1
Lamp Life	35K
Screen Resolutions	VGA-SXGA
Native Resolution (Best Picture)	XGA
Vertical Frequency Range	50-75Hz.
Horizontal Frequency Range	15-61KHz.
PC Video Input	Separate Sync (5 Wire)
	Composite Sync (4 Wire)
	Sync On Green (3 Wire)
PC Video Interface	VGA (HD-15F) (Female)
Colors	24bit (16M)
View Angle Left / Right	70 / 70
View Angle Up / Dn	55 / 65
Input Voltage	90-264 VAC Auto-switching
Input power	25W
Current Draw	.20 /120VAC
Installed Depth	2.68"
Chassis Construction	16 Ga SS
Bezel Construction	Al Machined .250"
Bezel OD	17.56"x14.56"
Bezel Finish	Black Textured
Auto Adjust	Yes [On Power Up]
5 Wire Touch	Yes
Recessed Cable Exit	Yes
Operating Temp	0-50
Storage Temp	0-60
Storage Humidity	10-95
NEMA Front End	4/12

Appendix D – Mounting Dimensions

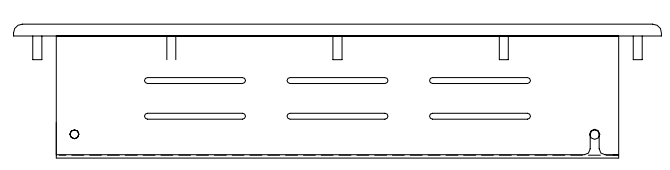
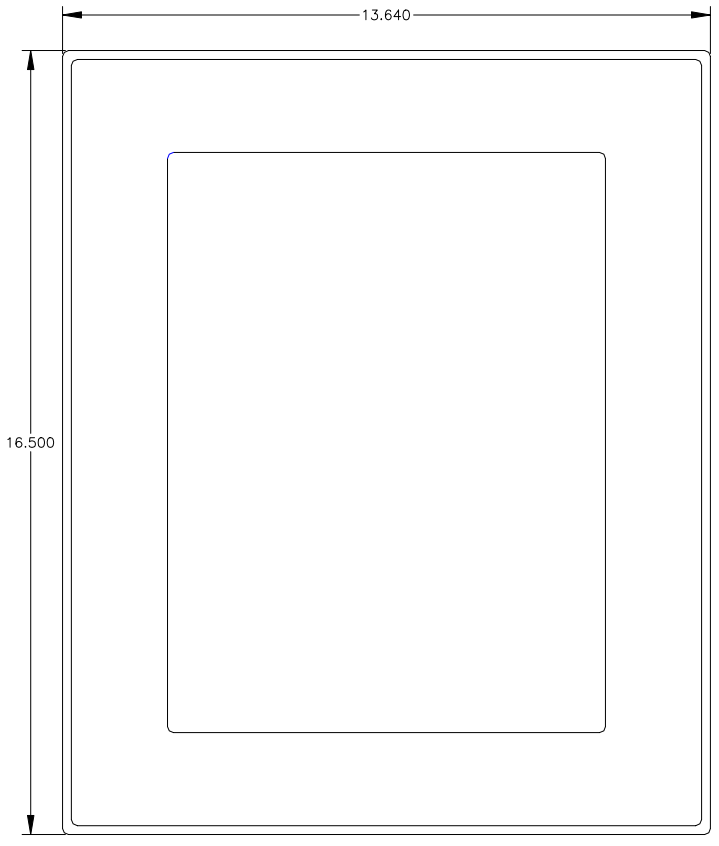
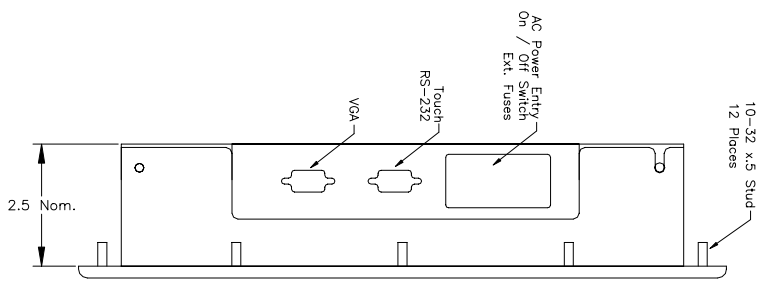

REV	DATE	BY	CHKD	APP'D	DESCRIPTION
1					
2					
3					
4					
5					

THIS DRAWING AND THE INFORMATION CONTAINED THEREIN ARE THE PROPERTY OF INDUSTRIAL ELECTRONIC DEVICES, INC.		TOLERANCE UNLESS OTHERWISE SPECIFIED		Industrial Electronic Devices 13 Independence Rd. Suite 100 San Marcos, CA 92069	
DIMENSIONS UNLESS OTHERWISE SPECIFIED	FINISHES UNLESS OTHERWISE SPECIFIED	MATERIALS UNLESS OTHERWISE SPECIFIED	QUANTITY UNLESS OTHERWISE SPECIFIED	DATE UNLESS OTHERWISE SPECIFIED	DRAWING NUMBER UNLESS OTHERWISE SPECIFIED
DIMENSIONS UNLESS OTHERWISE SPECIFIED	FINISHES UNLESS OTHERWISE SPECIFIED	MATERIALS UNLESS OTHERWISE SPECIFIED	QUANTITY UNLESS OTHERWISE SPECIFIED	DATE UNLESS OTHERWISE SPECIFIED	DRAWING NUMBER UNLESS OTHERWISE SPECIFIED
DIMENSIONS UNLESS OTHERWISE SPECIFIED	FINISHES UNLESS OTHERWISE SPECIFIED	MATERIALS UNLESS OTHERWISE SPECIFIED	QUANTITY UNLESS OTHERWISE SPECIFIED	DATE UNLESS OTHERWISE SPECIFIED	DRAWING NUMBER UNLESS OTHERWISE SPECIFIED

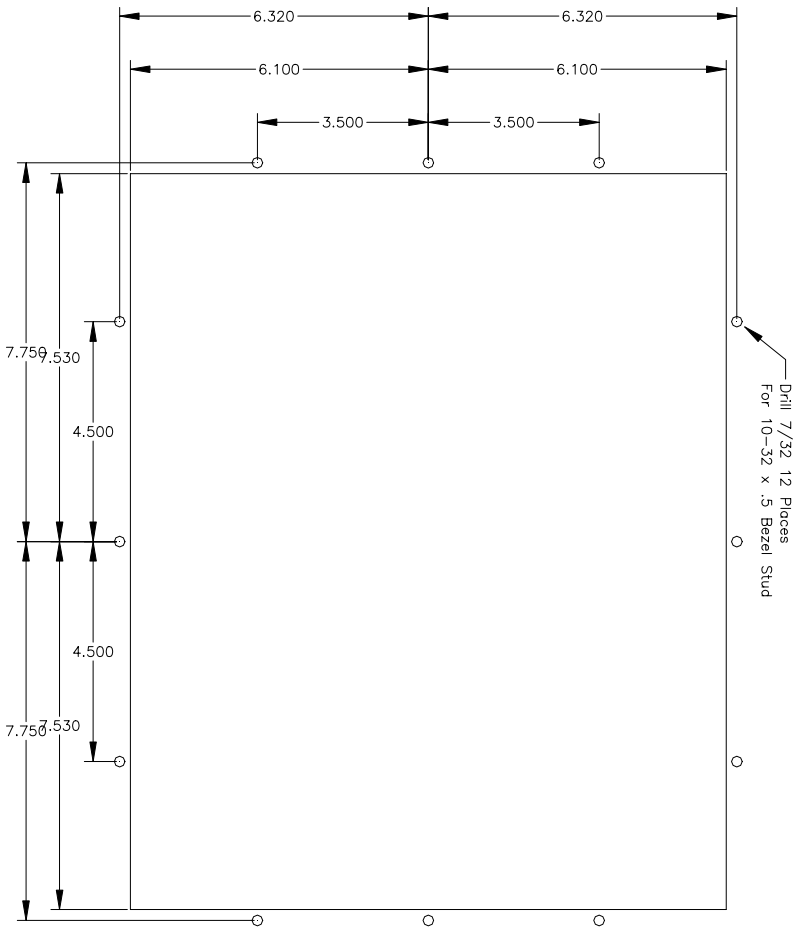

DATE	BY	CHKD BY	REVISED	REVISION
5/20/14				

<p>THIS DRAWING AND THE INFORMATION CONTAINED HEREIN ARE THE PROPERTY OF INDUSTRIAL ELECTRONIC DEVICES. THIS DRAWING OR ANY PARTS THEREOF ARE TO BE KEPT IN CONFIDENTIALITY AND NOT TO BE REPRODUCED BY ANY MEANS WITHOUT THE WRITTEN PERMISSION OF INDUSTRIAL ELECTRONIC DEVICES.</p>	
INDUSTRIAL ELECTRONIC DEVICES	INDUSTRIAL ELECTRONIC DEVICES
15 WASHINGTON ROAD ROSELAND, NJ 07068	15 WASHINGTON ROAD ROSELAND, NJ 07068
DATE: 4/6/09	DATE: 4/6/09
DRWING NO: FPM154	DRWING NO: FPM154
REV: E	REV: E

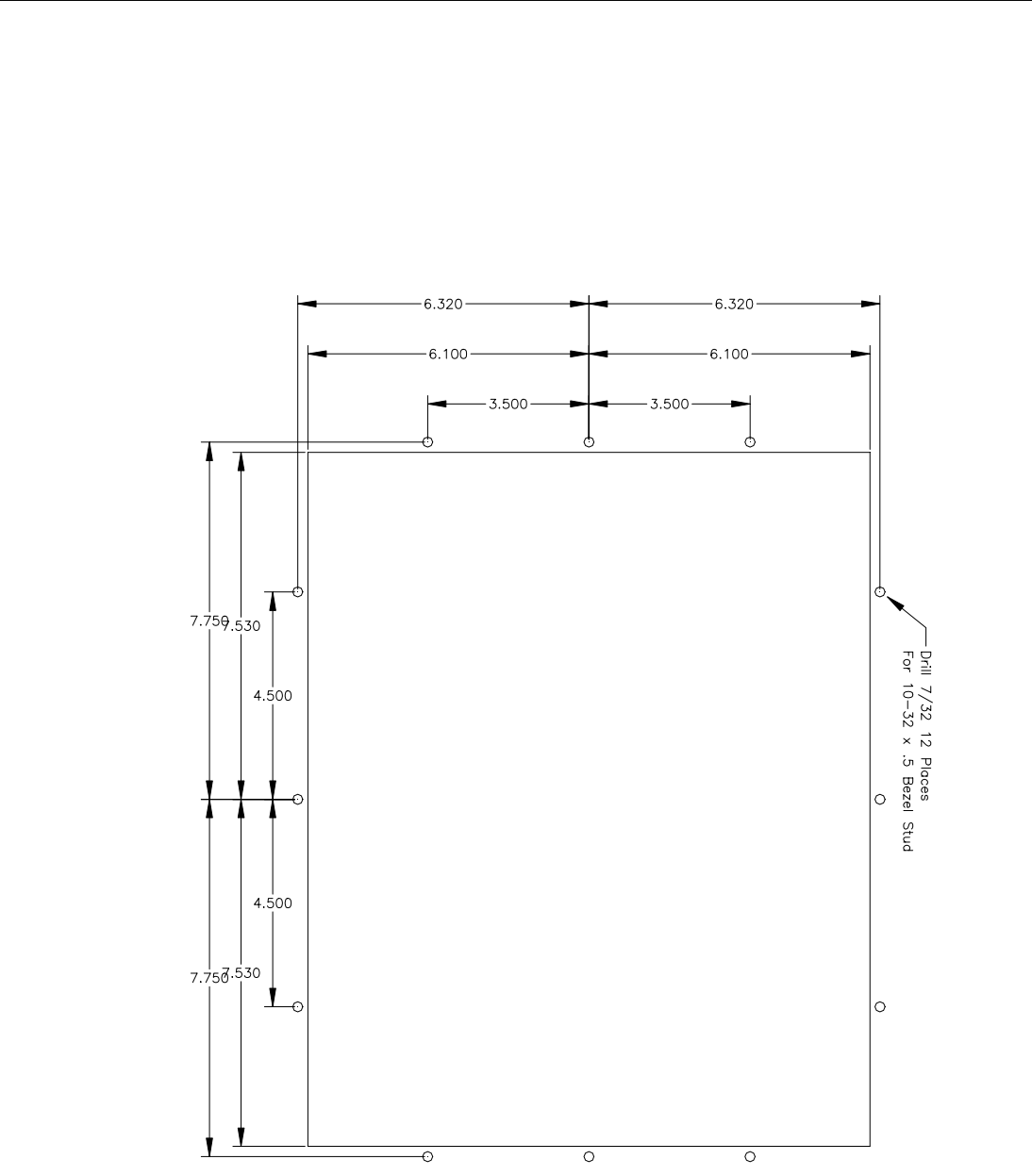

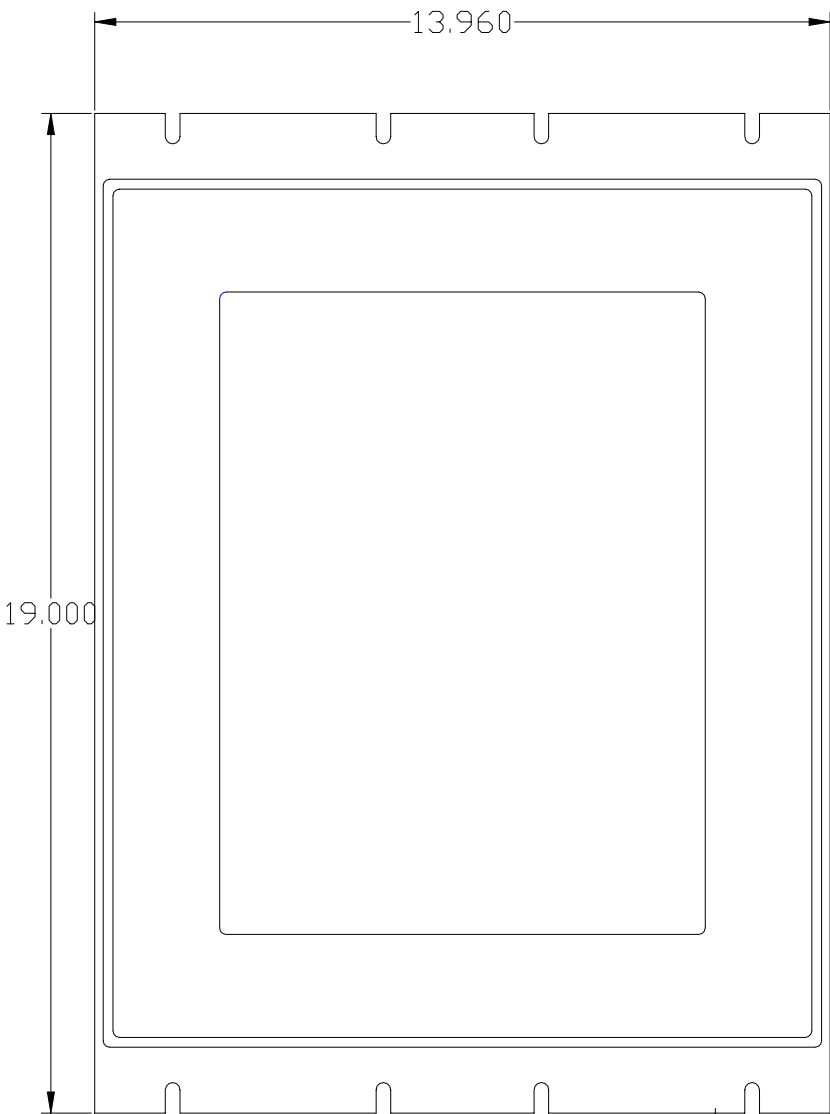

FPM-140/15(T) and FPM-154(T) Shown With
Optional 19" Rack Mount Adapter [8U]

TOLERANCE		Industrial Electronic Devices	
STANDARD	AS SHOWN	FORMING	AS SHOWN
WELD	AS SHOWN	FINISH	AS SHOWN
ROUNDED	AS SHOWN	DRILLING	AS SHOWN
INDUSTRIAL ELECTRONIC DEVICES		INDUSTRIAL ELECTRONIC DEVICES	
PART NUMBER IS		PART NUMBER IS	
PROJECT PART AND IS NOT TO		PROJECT PART AND IS NOT TO	
BE USED, SUBSTITUTED, LAMINATED,		BE USED, SUBSTITUTED, LAMINATED,	
OR ADAPTED WITHOUT EXPRESS		OR ADAPTED WITHOUT EXPRESS	
WRITTEN CONSENT		WRITTEN CONSENT	
DATE	4/9/00	DATE	4/9/00
BY	FPM_154_RM	BY	FPM_154_RM
APP	A	APP	A

NOTES

Model Number: _____

Serial Number: _____